



# Hoist Ring SAFETY INSTRUCTIONS

## CAUTION: PRIOR TO USING ANY HOIST RING, PLEASE READ THE FOLLOWING FOR PROPER INSTALLATION AND USAGE.

As with all mechanical devices, regular inspection for wear and strict adherence to use instruction is necessary to prevent misuse failure.

- Despite the 5:1 safety factor, NEVER EXCEED THE RATED LOAD CAPACITY. This safety margin is needed in case of misuse, which could drastically lower load capacity.

- Tighten mounting screws to recommended torque. Periodically check torque because screws could loosen with extended service.

- Tensile strength of parent material should be above 80,000 PSI to achieve full load rating. For weaker material, consider through-hole mounting with a nut and washer on the other side.

- AVOID SHOCK LOADING. Always lift gradually. Repeat magnetic particle inspection if shock loading ever occurs.

• After installation, always check that ring rotates and pivots freely in all directions.

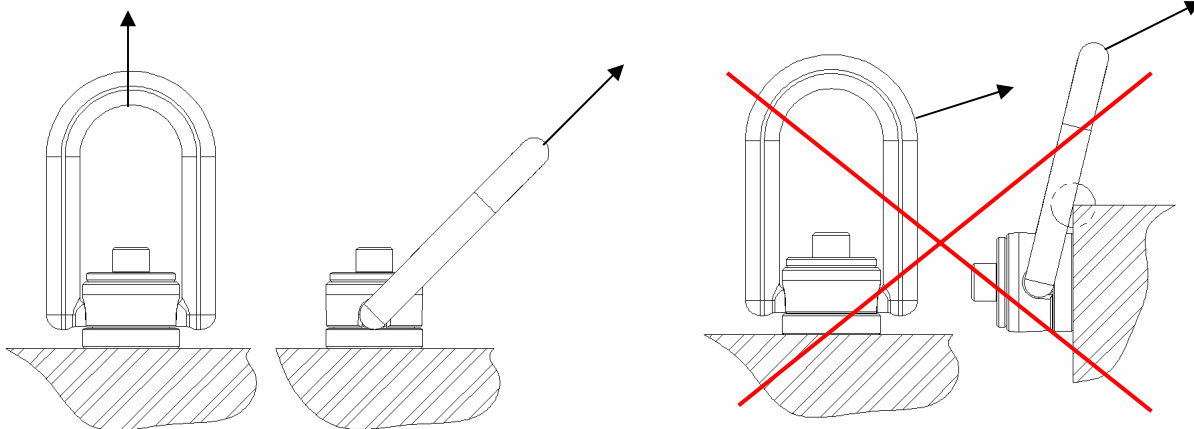

**CORRECT**

**INCORRECT**

**IMPORTANT!** The force on each hoist ring is not just the total weight divided by the number of hoist rings. The force will be greater at lower lift angles. Make sure load is evenly distributed. See below.

Formula with example data:

$$F = W / N \sin A$$

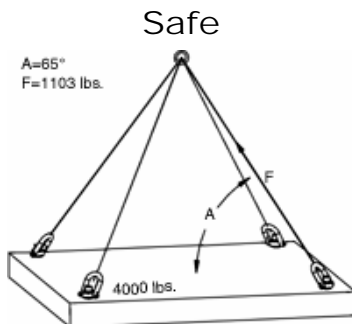

**Fig. 1**

**A = 65 °**  
**F = 4000 / 4 sin65 ° = 1103 lbs.**

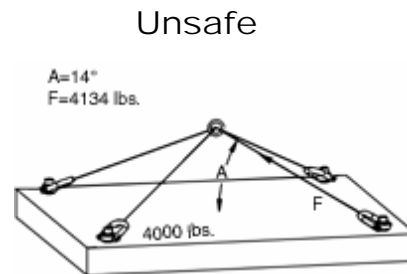

**Fig. 2**

**A = 14 °**  
**F = 4000 / 4 sin14 ° = 4134 lbs.**

F = Force on each hoist ring  
W = Total weight = 4000 lbs.  
N = Number of hoist rings = 4  
A = Lifting angle